

OWNER'S MANUAL

with SET UP INSTRUCTIONS

for **JACOBSEN**

21" MANOR MOWER



NO. 22114 (5 BLADE)

SERIAL NO. 51151 AND UP

NO. 22121 (7 BLADE)

SERIAL NO. 52507 AND UP



JACOBSEN MANUFACTURING COMPANY
RACINE, WISCONSIN 53403

Part No. 344196

FOREWORD

This Owner's Manual is your guide to proper mower operation.

The simple maintenance suggested on the pages of this handbook will prolong the efficiency and life of the mower. It is suggested that you read this manual thoroughly in its entirety before operating your mower. The more familiar you become with the mower and its operation, the better results you will have in its use.



CONTENTS

	Page
Definition Of Directions	4
Operating Instructions	4
Starting And Stopping Engine	4
Adjustments	4
Lubrication	6
Maintenance	7
Storage	7
Safety Suggestions	8
Accessories	9
Operating Instructions And Lawn Care	10
Specifications	11
Set - Up Instructions	11
How To Order Parts	13
Warranty	13

DEFINITION OF DIRECTIONS

Reference to "right" and "left" hand side of the mower is from the operator's position at the handle.

OPERATING INSTRUCTIONS

TRACTION CLUTCH LEVER

The lever on the left side of the control panel engages traction clutch to place mower in motion. The lever has two operating positions. Pushing lever forward, or away from operator, engages the clutch for forward motion. Pulling lever rearward disengages clutch.

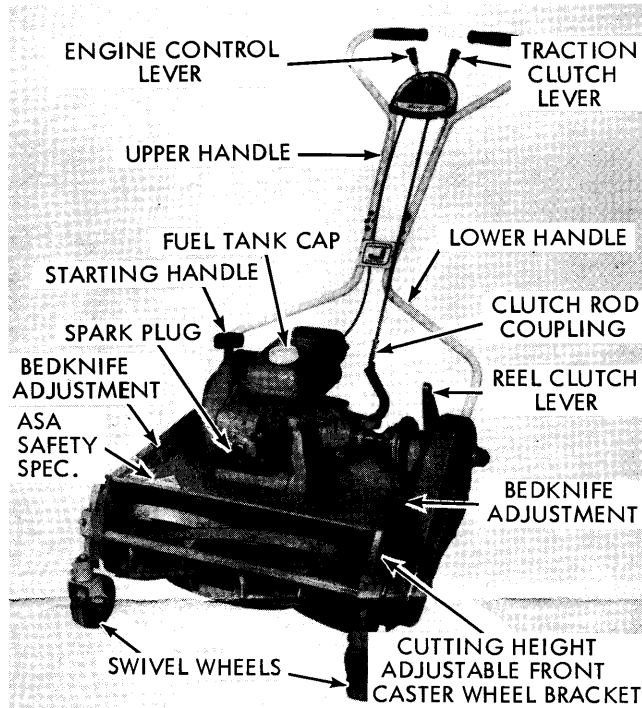

Figure 1.

REEL CLUTCH

The reel clutch handle is located on left hand side of deck next to belt guard. To engage clutch, move handle rearward towards rear of mower. To disengage clutch, move handle forward towards front of mower.

WARNING

Reel clutch cannot be engaged unless engine is running. An attempt to engage clutch when engine is stopped may result in breakage of clutch parts.

To put mower in motion - start engine.

Before starting engine check mower against set-up instructions to assure mower is properly assembled. Review safety suggestions and operating instructions for safe and proper use of mower.

OPERATING MOWER

Engage traction clutch by pushing clutch control lever all the way forward to "run" position.

To stop forward motion, disengage traction clutch by moving clutch lever to "neutral" position.

Engage reel clutch. If mower is being transported, keep reel clutch in disengage position. Before engaging reel clutch place traction clutch in "neutral".

CAUTION

If an object is caught in cutting unit, immediately disengage reel clutch to remove power from reel. Stop engine and remove spark plug wire from plug before attempting to remove object from reel.

STARTING AND STOPPING ENGINE

STARTING ENGINE

1. MAKE CERTAIN CLUTCH CONTROL LEVER IS IN "NEUTRAL" POSITION.
2. Make certain reel clutch lever is in the disengaged position.
3. Check spark plug wire for proper connection on spark plug. See engine manual.
4. Check fuel supply and open fuel tank shut-off valve. Refer to engine manual for proper fuel and oil requirements.
5. Set throttle lever to the "choke" position on the "Choke-Run-Stop" control (See figure 2).
6. Grasp the starter handle firmly and pull slowly and firmly to crank the engine.

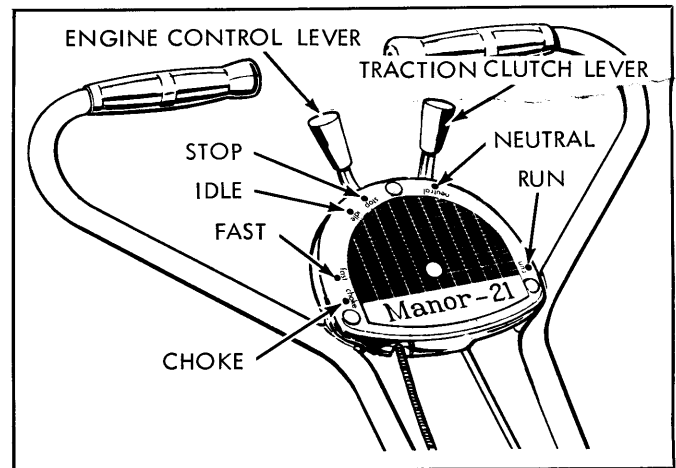

Figure 2.

When engine starts, move throttle lever to a "run" position. Partial choking may be required while engine is cold.

To get the most efficient operation from your mower, run engine at three-quarter to full throttle to best fit cutting conditions.

STOPPING ENGINE

Move throttle control to "stop" position.

ADJUSTMENTS

CLUTCH ROD ADJUSTMENT

Clutch Rod Length

The length of the clutch rod can be varied by the adjustable coupling on the end of the rod that attaches to the clutch lever on the mower deck. A high handle position for a tall operator will require shortening the rod. A low handle position for a short operator will require lengthening the rod.

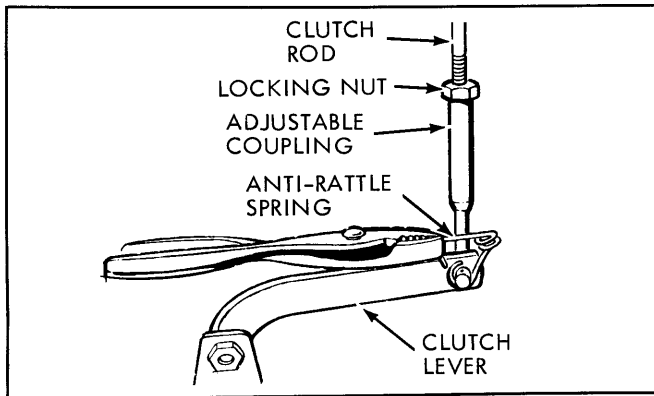

Figure 3.

To Adjust:

1. Remove anti-rattle spring.
2. Remove adjustable coupling from lever.
3. Loosen locking nut on coupling.
4. Lengthen or shorten as required.
5. Tighten locking nut and replace.

The clutch lever on the upper handle must completely engage and disengage the traction clutch when rod length is correctly adjusted for any selected handle height.

TRACTION CHAIN ADJUSTMENT

1. Place blocks under side frames to raise rollers off ground.
2. Loosen four (4) traction bearing housing screws in each side frame.
3. Force rollers in downward direction until chain slack is removed.
4. When chain slack is removed (avoid over-tightening of chain), tighten screws in bearing bracket to hold adjustment.

CAUTION

Both right and left bearing brackets must be positioned equally in side frames when making this adjustment. Check carefully for straight alignment.

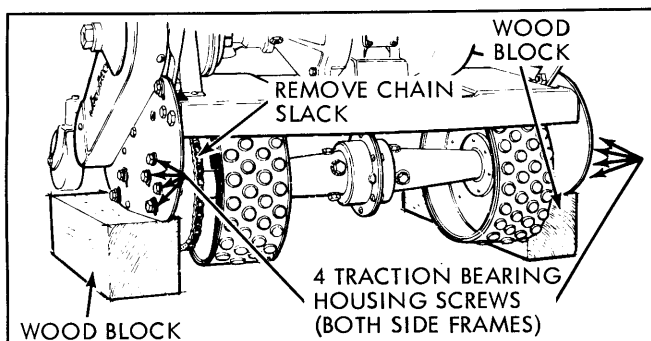

Figure 4.

TRACTION CLUTCH ADJUSTMENT

Should the traction clutch fail to hold properly, it can be adjusted by loosening the fillister head screw in the collar and tapping the collar toward the clutch disc a slight distance. Retighten screw on collar. Proper adjustment will permit easy operation of the clutch without any slippage.

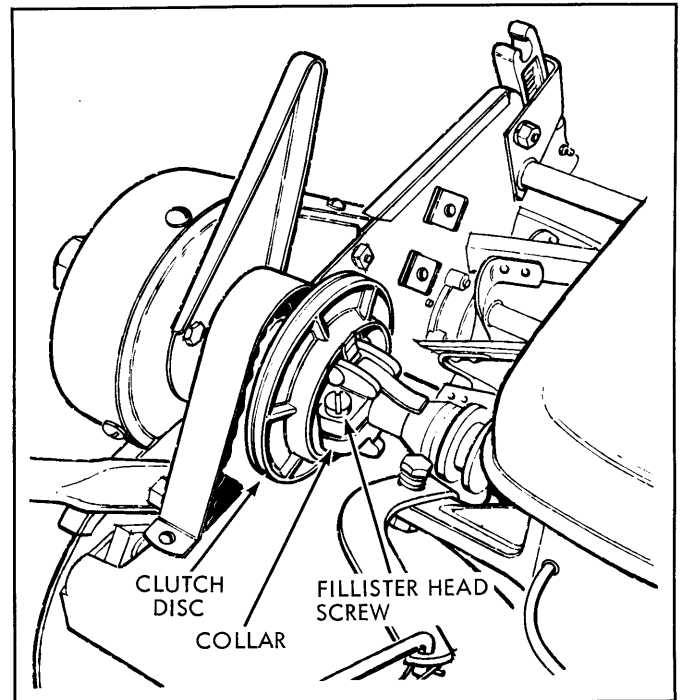

Figure 5.

REEL DRIVE BELT ADJUSTMENT

NOTE

After the first 8 operating hours, check reel drive belt for slippage and adjust if required. Then check for belt slippage every 40 operating hours thereafter.

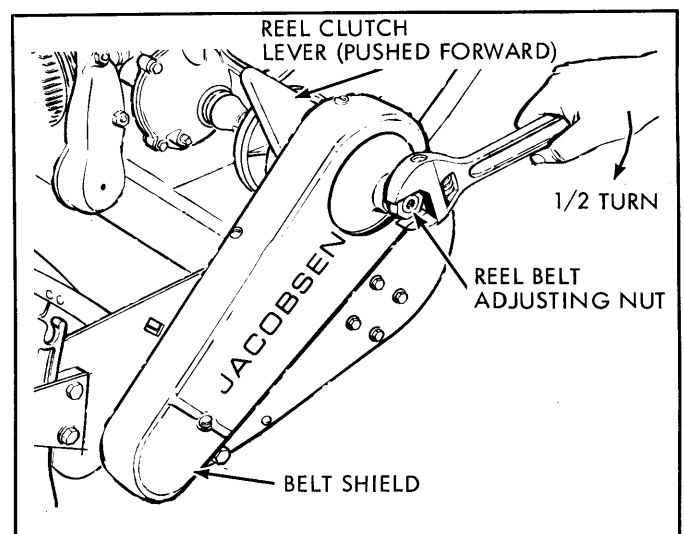

Figure 6.

Slippage of reel drive belt can be caused by insufficient belt tension, or by grease and oil on belt.

To check belt for slippage:

1. Place traction clutch lever in neutral and start engine. Engage reel clutch and stop engine.

WARNING

Reel clutch cannot be engaged unless engine is running. An attempt to engage clutch when engine is stopped may result in breakage of clutch parts.

2. Remove spark plug wire from plug. Engage traction clutch. Place right hand on traction clutch and left hand on reel. With left hand pull up on reel (turn reel backwards) with the right hand holding traction clutch. If reel can be turned without turning clutch, belt should be adjusted.

To adjust reel drive belt tension:

1. Keep reel clutch engaged. With left hand hold reel from turning while using a wrench to turn reel belt adjusting nut clockwise about one-half (1/2) turn. Disengage reel clutch and follow procedure for checking reel belt for slippage. Engine must be started and reel clutch engaged to reposition clutch and drive belt after adjusting nut has been turned. If slippage still occurs, turn nut clockwise in one-half (1/2) turn trials and repeat procedure for checking for slippage until proper belt tension is obtained.
2. About every 40 operating hours belt shield should be removed and belt condition checked. Belt slippage may occur because of grease and oil on belt. To clean belt: Use naphtha cleaning fluid or gasoline to dampen a cloth; do not saturate to the extent that cleaner will wet the belt. Wipe belt clean and remove any excess cleaner from belt with a dry cloth. Replace belt shield and check for belt slippage.

BED KNIFE ADJUSTMENT

To adjust the bed knife to the reel proceed as follows:

1. Disengage the reel clutch so the reel can be freely revolved by hand.
2. On each side frame of the mower, a bed knife adjustment nut adjusts the bed knife to the reel. Turn the adjusting nuts counter-clockwise to bring knife towards the reel and clockwise to move knife away from the reel.
3. Revolve reel by hand, tighten or loosen adjusting nuts equally until the bed knife just come in contact with the reel blades. When correctly adjusted, each blade will cut a strip of newspaper along the entire width and the reel can be spun freely by hand.
4. **TEMPORARY SHARPENING ONLY.** If the cutting edges are dulled or nicked, they can be temporarily sharpened. Adjust bedknife tighter than recommended to create tightness to reel blades and bed knife.

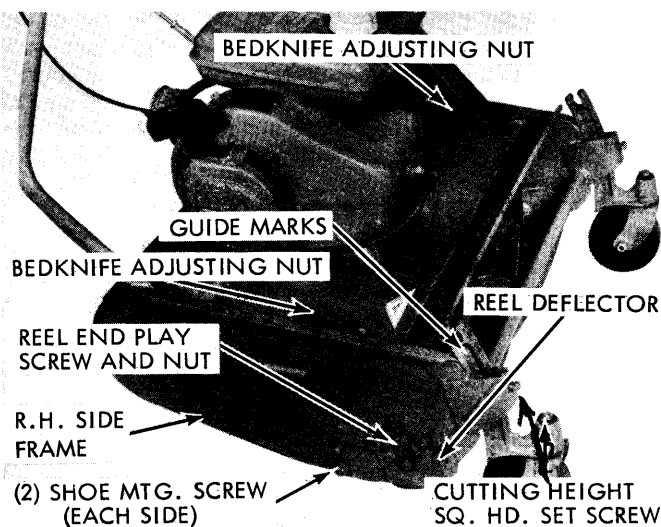

Figure 7.

IMPORTANT

Adjust bed knife evenly at both ends to prevent uneven wear.

Operate reel at slow speed for a short period of time. Then readjust as explained in Paragraph 3.

CAUTION

Avoid excessive reel to bed knife tightening or serious damage may result to the bed knife and reel. Excessive tightness causes undue wear to reel blades and bed knife and requires more power from the engine.

See your Jacobsen Dealer for regrinding of reel and bed knife when mower needs re-sharpening.

REMOVING END PLAY IN REEL

The reel must be kept free of end play. Adjust as follows:

1. Disengage the reel clutch so the reel can be freely revolved by hand.
2. Loosen the locking nut on end play screw located in the right hand side frame.
3. Turn screw clockwise until end play is removed. Tighten nut to hold adjustment.
4. The reel must spin freely after this adjustment; do not overtighten screw.

LUBRICATION

CHASSIS LUBRICATION

Fill pressure gun with good quality semi-fluid type pressure gun grease (do not use cupgrease) and apply to grease fittings as follows: (See figure 8).

- A. Reel bearings (2): Lubricate every 40 hours.
- B. Outer rear roller shaft bearings (2): Lubricate every 40 hours.
- C. Inner rear roller shaft bearings (2): Lubricate every 40 hours.

NOTE

Differential assembly is packed at the factory for a full seasons use.

- D. Reel clutch bearings. The reel clutch must be disengaged (handle in NEUTRAL) when greasing the bearings through the grease fitting in end of clutch shaft, otherwise some moving parts will not be properly lubricated. Grease may be forced into the belt housing if the clutch is greased while in the engaged position or if too much grease is applied. A moderate amount of grease, two or three strokes from the grease gun should be applied after each 40 hours of operation.

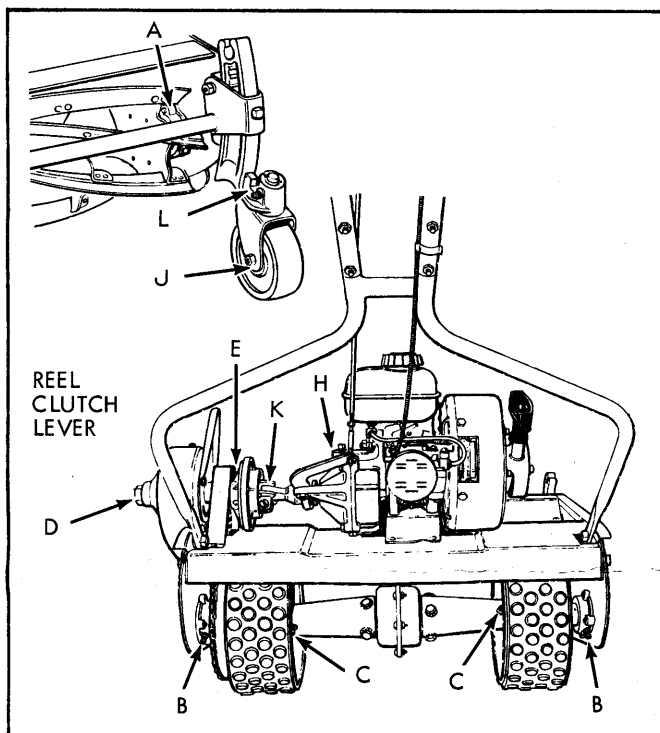

Figure 8.

CAUTION

The reel clutch handle is in forward position when disengaged and a rearward position when engaged. The clutch cannot be engaged unless the engine is running. An attempt to engage the clutch with the engine stopped may result in breakage of clutch parts.

- E. Traction drive sprocket bearing: Ball Oil Cup-Lubricate daily with 2 or 3 drops SAE No. 30 oil.
- H. Speed reducer housing on engine: The oil level in the speed reducer must be checked every thirty (30) days during the cutting season. Remove the pipe plugs at H and I. Fill housing with SAE No. 30 oil to level of hole at I. Replace plugs tightly.
- J. Guide wheel bearings (2): Lubricate daily. (Fitting in end of shaft).
- K. A few drops of oil of type used in lubricating engine should be applied daily to clutch sleeve and clutch fingers.
- L. Caster bracket bearings (2): Lubricate daily.

OILING ROLLER CHAIN

For long chain life oil must be applied every 8 hours of operation to the upper sideplates so that oil reaches the inside of each roller. See illustration on how to correctly oil roller chain.

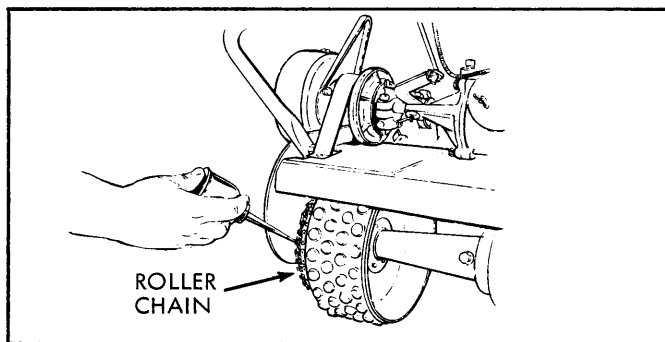

Figure 9.

LUBRICATING CONTROL CABLE

If control cable becomes hard to operate, lubricate outside of control housing with #30 oil. Oil will run between coils in housing and lubricate inside of housing. Wipe off excess oil that remains on the outside of housing.

MAINTENANCE

ENGINE MAINTENANCE (See Engine Manual)

1. Periodically check (Clean if Required) the air intake screen of the engine to prevent engine damage caused by overheating or overspeeding.

STORAGE

STORING MOWER

At the end of the season, or if mower is to be stored for any length of time, the following steps are recommended.

Wash off accumulated dust and clippings with spray from garden hose, being careful not to direct force of water at air cleaner. If necessary a soft bristled scrub brush can be used to clean wheels and tires.

A small stick can be used effectively to clean out corners.

Wipe entire unit with clean cloth to remove gasoline stains and oily spots. This simple procedure will keep your mower looking like new for years to come.

When mower is completely dry, lubricate mower. Follow lubricating instructions in maintenance section of this manual.

Close the fuel valve, start and run the engine at 3/4 throttle until fuel in the carburetor is used up and engine stops.

Then refer to ENGINE INSTRUCTIONS MANUAL for storage instructions. Be faithful to these simple procedures and your Jacobsen mower will give you faithful service year after year.



SAFETY SUGGESTIONS FOR ALL POWER MOWER USERS

Recommended practices from the American Standard Safety Specifications for Power Lawn Mowers

TRAINING

1. Regard your mower as a piece of power equipment, and teach this regard to all who operate the equipment.
2. Never allow children or young teen-agers to operate a power mower.
3. Be sure you know how to stop the mower and engine at a moment's notice.
4. Instruct children to keep away from the area of operation of the mower at all times.

PREPARATION

1. Before starting operation, clear the entire lawn area of all debris that could catch on to or be thrown by the blade.
2. Plan the cutting operation so it is not necessary to pull the mower rearward towards you, particularly on a downgrade.
3. When you mow on rough terrain or in high grass or weeds, the blade should be set at the highest cutting point to minimize debris being ejected from the mower.
4. Unless there is very good artificial light, mow only during the daylight.
5. Do not operate power mowers in wet grass, which clogs the mower and increases the danger of your slipping and possibly coming into contact with the blade.
6. Fill gasoline-driven mowers outdoors. Avoid spilling gasoline and don't fill the tank while engine is running or while you are smoking. Don't mow when barefoot or wearing open sandals.
7. Provide some protection by means of long, heavy denim trousers and brogues. If you have safety shoes, wear them.
8. Mower guards should never be removed.

OPERATION

1. Give complete and undivided attention to the job at hand.
2. Keep the area of operation clear of all persons, particularly small children.
3. Don't start the motor or engine and blade until you are ready to start mowing. Stop the engine whenever you leave the mower.
4. Don't overspeed the engine. Excessive cutting speed or tampering with the governor can be dangerous. Operate the engine at the slowest speed which will cut satisfactorily.

5. Start the mower carefully. Stand firmly, with your feet away from the blade. Be sure the mower will not tip or roll during the starting operation.
6. If the mower handle has a safety latch to hold it in normal operating position, keep it engaged during the operation.
7. Keep in step with the mower. Do not lag behind or let it pull you so you will not be in full command of the machine. Do not run.
8. Control the direction of the mower by hand pressure on the handle, not by foot pressure on the mower housing.
9. When operating the mower, use the handle to push or pull the mower; do not push or pull on the deck with your hands or feet.
10. When operating over uneven terrain and slopes, use extreme care and make sure of solid and firm footing at all times.
11. Exercise special care when mowing around objects to prevent the blades from striking them and never deliberately mow over any object.
12. Stop operation when another person approaches. Do not pass or stand on the grass-discharge side of the mower with the engine running.

MAINTENANCE AND STORAGE

1. Follow implicitly the manufacturer's recommendations for maintenance.
2. Have a competent serviceman make a thorough inspection of the mower at least once a year.
3. Never adjust the mower or change attachments until the engine has been turned off and the spark-plug wire disconnected. Otherwise it is possible that the engine could start while making an adjustment or repair.
4. If carburetor adjustment is necessary, stand to one side and keep feet and hands in the clear while making adjustments.
5. Keep engines free from accumulations of grass, leaves, or excessive grease. An accumulation of these combustible materials may result in a fire.
6. Store gasoline in safe container. Store the container in a cool, dry place, not in the house or near heating appliances.
7. Keep the mower and fuel container in locked storage to prevent children from playing and tampering with them.
8. Maximum mowing results and safety can only be expected if the mower is maintained and operated correctly.
9. Gasoline powered equipment or fuel containers should not be stored in basement or any closed area where heating or heat appliances or open pilot lights are present, unless fuel is completely drained from power equipment and fuel containers.

ACCESSORIES

The following Accessories are available for your Mower from your Jacobsen Dealer.

Grass Catcher - No. 58130

Gyro Starter - No. 58397

Riding Sulky - No. 58000

Snow Plow - No. 58300

Dual Wheel Kit - No. 58500

A.C. Electric Starter

A 110 volt A.C. operated electric starter with integral automatic rope rewind starter is available for your mower. Fast, sure starting without the worry of a battery. For additional information see your Jacobsen Dealer.

Until you become familiar with your mower, it is advisable at first to mow a level area. This will give you an opportunity to get the "feel" of the mower. You may want to adjust the handle to a more comfortable height. You'll discover the proper speed for clean cutting of your particular lawn.

On hillside cutting it is safest to cut along the side of the hill instead of up and down. This method is the only practical way to mow a rather steep incline. This places operator away from unit if he slips. It also reduces scalping on crown of hill.

MOWING PATTERNS

Care of the lawn includes use of the lawn mower to enhance the overall appearance of your lawn and home. By changing the mowing direction, various mowing patterns can be made to get advantages in landscaping and in lawn care. Reversals and changes of direction every week will help to eliminate matting, graining and corrugations. Instead of mowing in circles, try a pattern variation to get additional mowing benefits.

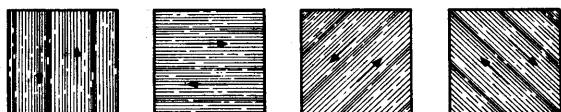

Figure 10.

HOW TO TRIM

Trimming with the Manor can reduce a good portion of hand trimming around flower beds, curbs, foundations, walls, trees and fences. For any border trimming which allows an overhang of the mower use the right side of the mower (from operator's position). Keep one half the width of the right roller on the trim side of the lawn which allows about 2 inches of the mower to cut beyond the lawn edge. The mower will retain its balance with this overhang and cut a level path with a clean cut edge. For trimming next to foundations, walls, trees, and fences, keep the right side of mower as close to the border as possible. Mow at a reduced speed and ease the clutch into position gradually for traction.

A 4-Roller Kit is available for greater stability of the mower. Intricate flower bed designs are more easily trimmed with a mower having four rollers when following extreme angles or reverse curves.

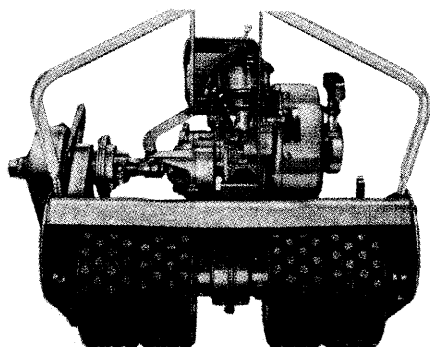

Figure 11.

Your Manor mower will mow any lawn to show it off to its best advantage. However, proper lawn maintenance is required to insure your satisfaction with the finished cut.

Proper fertilizing, weed and insect control are means of maintaining a good lawn. Since conditions in each locale vary and personal preference is so great, it is impossible to cover all the variations. It is recommended you consult your local garden supply dealer for the lawn care instructions required for your particular needs. Local county agents, parks and golf course superintendents are excellent sources of information in proper grass maintenance for your area.

WATERING

It is recommended your lawn be watered to equal 1 to 2 inches of rain each week when natural rain does not provide this amount. This should be done in one deep watering to stimulate root growth. Light, frequent watering promotes weak grass growth and strong weed growth.

SELECT PROPER CUTTING HEIGHT

The Jacobsen Manor is a precision cutting mower for all types of grass. Cutting height is easily adjusted from 5/16 inches to 1-1/2 inches depending upon your requirements. Hot, cool, moist and dry periods during the grass growing season require different heights of grass. During hot and dry periods keep grass at 1-1/2 inch height and for cool and moist periods 1 inch or shorter is recommended.

Good lawn care promotes thick turf and will allow you to reduce cutting heights. There are times when your mower will not seem to perform as well you expect it to. Follow these tips to provide best results.

STREAKING

Caused by wheel tracks, limp grass. Grass too high. Cut grass shorter, more frequently. Do not cut when grass is wet. If grass is too long, cut twice. First time about 1/2 inch above desired finished cut. To eliminate wheel tracks, overlap cut going in direction opposite to first cut.

USE OF GRASS CATCHER

Catcher not included with mower, order from your dealer.

The Catcher for the Manor is specially designed to fill completely with grass clippings and lawn debris. Use of the grass catcher requires simple installation of a forward throwing deflector. The catcher is easily and firmly hooked on the front swivel brackets. The grass catcher is recommended during two periods of the grass mowing season: in the spring when the grass is moist and fast growing, and in late summer when weeds and obnoxious grasses are forming seeds.

SPECIFICATIONS

Engine: Type - Jacobsen 321 Super Torque Engine
Horsepower - 3
Starter - Automatic Rewind

Fuel: See Engine Manual

Reel: 5 blade - 6 inch diameter

Cutting Width: 21 inches

Cutting Height: 5-16 inch to 1-1/2 inch

Front Wheels: Caster type

Rear Wheels: Traction drive rollers

Traction Clutch: Disc type

Reel Clutch: Variable Sheave

SET-UP INSTRUCTIONS

Your Jacobsen Manor mower is completely packed in one carton. Carefully unpack mower and handle and assemble as follows:

NOTE

Control panel assembly is attached to engine by flexible engine control cable.

INSTALLING HANDLE (Figure 12).

1. Assemble upper and lower handle sections. Install the screws and lock nuts holding the handle together, tighten securely.
2. Slip lower end of handle over stud on inside of left hand side frame, then spring handle in and slip lower right end of handle over stud on right hand side frame.
3. Remove 2 bolts, 2 nuts and 4 washers from bag of parts. Place a large washer on each side of frame. Insert bolt through washer and slot in side frame, then through another washer, and screw into threaded hole in handle. Secure tightly at desired height. Lock setting by means of nuts provided.
4. Some operators prefer a free floating handle. To secure, loosen lock nut on handle screw and loosen screw two turns. Tighten lock nut securely. Handle will then be free floating and rest against handle stop. The handle stops may be rotated into any of four positions by loosening the stop mounting screws. Turn stop to provide a convenient minimum handle height and tighten screw.

INSTALLING CONTROL PANEL ASSEMBLY (Figures 12 & 13).

1. Unwind engine control cable and control panel assembly from around engine. Pass control panel assembly under crosspiece on lower section of handle and place panel at top of handle. Insert flexible engine control cable wire into spring clip and snap clip on handle between section bolts with cable towards the inside.

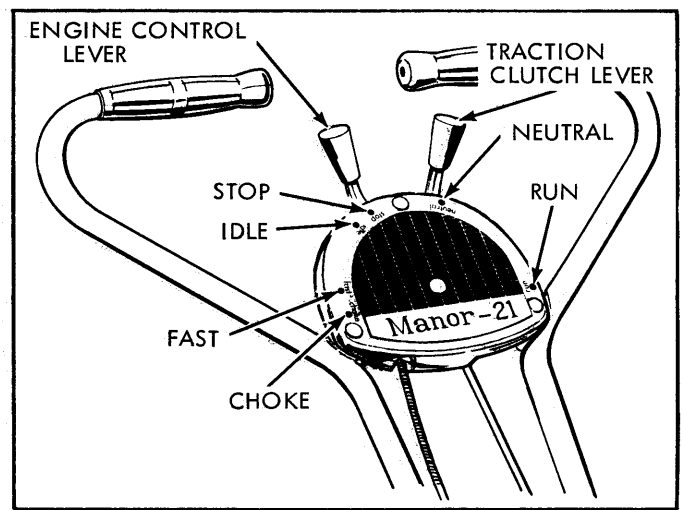

Figure 12.

2. Insert long bent end of clutch control rod (not the adjustable coupling end) through hole in clutch control lever on control panel and secure with cotter pin. Clutch control rod must be located on top of handle.
3. Attach control panel assembly to handle using spacer, 3 bolts and nuts. Spacer is used with top bolt between panel and handle.
4. Insert the adjustable coupling end of clutch control rod through hole in clutch operating lever on mower from top side down. See illustration. Secure with anti-rattle springs as follows: slide looped end over rod, then with a pliers slide straight end through hole in rod. (See Clutch Rod Adjustment on page 7).
5. Check operation by pushing clutch control lever forward to engage clutch and to start forward travel of mower. (This test must be made with engine operating.)

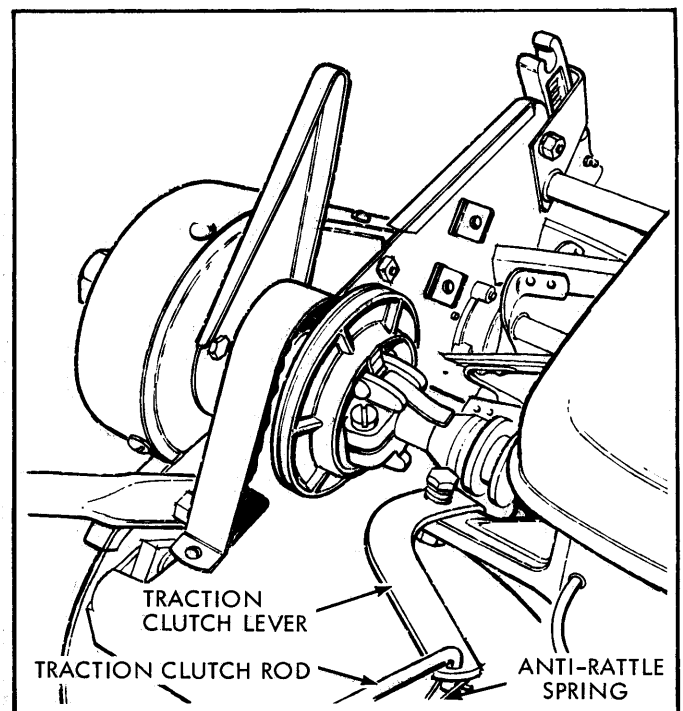

Figure 13.

NOTE

FOR THE INITIAL CUTTING WE RECOMMEND THAT CUTTING HEIGHT BE SET FOR A MEDIUM OR HIGH CUT FOR THE FIRST FEW HOURS OF OPERATION.

SETTING CUTTING HEIGHT (See Figure 14).

1. The cutting height of the mower can be set from 5/16" low to 1-1/2" high.
2. Set mower on a level surface and loosen the square head set screw on front edge of side frame bracket.
3. The raised bars in brackets serve as guide marks to set each wheel to same height.
4. Moving the brackets downward raises the cutting height. The cutting height is lowered by moving the brackets upward.
5. Measure the distance from the floor to the top edge of the cutter knife for cutting height desired.
6. Tighten square head set screws.

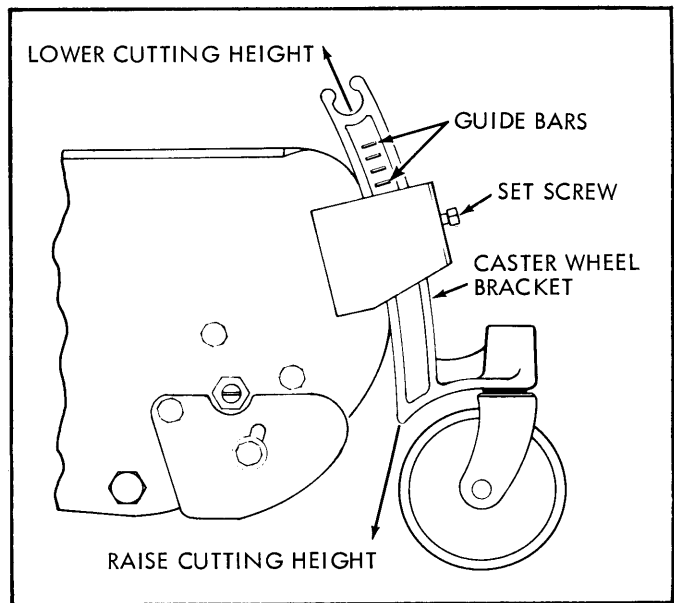

Figure 14.

ENGINE

Before you prepare the engine for operation, refer to the Engine Operating Instructions furnished with your mower. Read this manual carefully so that maximum efficiency and prolonged engine life may be obtained.

Check all nuts and bolts, including engine mounting nuts to see none has become loosened or lost in shipment. Tighten if necessary.

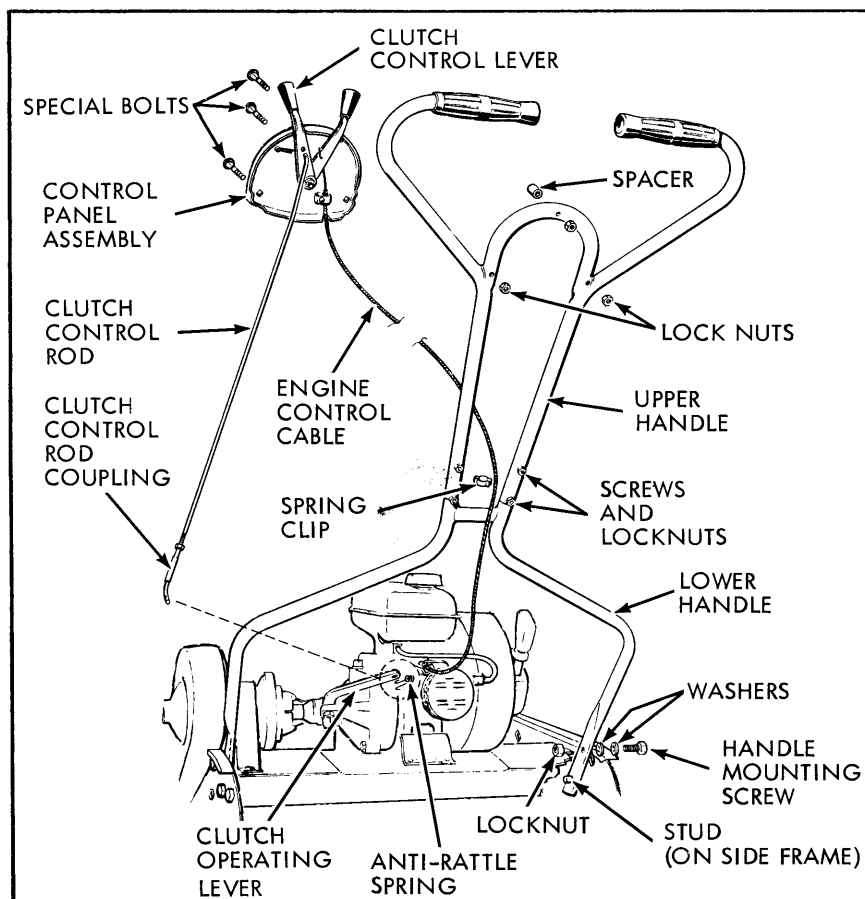

Figure 15.

HOW TO ORDER REPAIR PARTS

SEE YOUR JACOBSEN SERVICE DEALER

This manual is an operating and service guide for the owner. We do not recommend that you make major repairs beyond the necessary adjustments and simple repairs required to keep your mower in good operating condition. For assistance in getting the most out of your mower, and for overhaul, winter storage, tune-up, and repair service, we recommend your Authorized Jacobsen Dealer, who is prepared to help you.

Go directly to your local authorized Jacobsen Dealer for service and repair parts for your particular mower. Be sure you have correct product name, number, and serial number.

WHERE TO FIND PRODUCT NUMBER AND SERIAL NUMBER

Whenever it is necessary to use the product number and serial number of your mower, refer to the name plate located on the right frame.



WARRANTY

Jacobsen Consumer Products are guaranteed to the original retail purchaser against defective material and workmanship for **ONE YEAR** from date of purchase **OR FOR 45 DAYS IF USED FOR COMMERCIAL OR RENTAL PURPOSES**. The Jacobsen Manufacturing Company will replace defective parts free of charge f.o.b. any Jacobsen Service Station, except items warranted by the original manufacturer such as engines or other products that carry a separate warranty.

This warranty will not apply to Jacobsen products repaired or altered outside of a Jacobsen Service Station.

CUSTOMER PLEASE NOTE

Service related to normal maintenance items listed below under "Responsibility of the User" are not included under this warranty. Service required on these items will be furnished at reasonable prices.

RESPONSIBILITY OF THE USER

1. Adjustments to carburetor, ignition points or spark plug.
2. Adjustments made necessary through normal operation.
3. Sharpening of blades.
4. Failures resulting from accidental damage, misuse, improper care, negligence, or not lubricating properly.

The placing upon a Jacobsen product of any part or attachment not sold or approved by the Company shall void the warranty.

The company reserves the right to incorporate any changes in design without obligation to make these changes on units previously sold.

JACOBSEN MANUFACTURING COMPANY

NOTES

NOTES

A Careful Operator

**IS THE BEST INSURANCE
AGAINST AN ACCIDENT.**

— NATIONAL SAFETY COUNCIL



JACOBSEN MANUFACTURING COMPANY
RACINE, WISCONSIN 53403

LITHO IN U.S.A.